

Schäffer Lader

THE SPEZIAL SERIES

217 | 221 S | 222 S
326 S | 336 S | 442 S



**Functionality
in its most compact form**

YARD, WHEEL AND TELEHOIST LOADERS ...

from 14 kW (20 HP) to 115 kW (156 HP). We have been developing loaders to meet individual needs for nearly 50 years. Our satisfied customers have made us what we are today: One of the most capable and successful suppliers of yard, wheel and telehoist loaders in the market. Our associates develop new, tailor-made solutions every day. Each SCHÄFFER loader is the product of numerous years of experience and innovative developments. Our products set standards for exceptional reliability and long service life. With reduced operating costs throughout their entire service life. With yet more performance, safety and operating comfort for many years. This means ...

made by SCHÄFFER



THE SPEZIAL SERIES FROM SCHÄFFER: COMPACT LOADERS FOR AGRICULTURE

You require an articulating loader with maximum load capacity and lifting height. It has to be as compact as possible, with power to spare, yet economical to run. You expect simple, easily maintained technology with high reliability and the lowest possible investment cost.

The Spezial series from SCHÄFFER will meet your expectations in every way. Compact dimensions, proven technology and a timeless design make these machines unique. All this for an exceptionally low price. For these and other reasons, the more compact machines in this series continue to be among our best sellers.



THE SPEZIAL SERIES

217 15 kW (20 hp)	326 S 24 kW (32 hp)
221 S 19 kW (26 hp)	336 S 26,5 kW (36 hp)
222 S 19 kW (26 hp)	442 S 35 kW (48 hp)

UNIVERSAL APPLICATIONS

It is frequently the SCHÄFFER loader which have the highest operating hours of all machines in the yard. The wide selection of attachments, the compact machine dimensions, and the exceptionally high lift reach make these loaders into true workhorses. You will profit from the increased efficiency every day.

Utilize the freed-up space for other things. The value estimation of their owners is reflected in the high resale value. It's a machine you won't want to give up.



SCHÄFFER AXLES – THE SECURE FOUNDATION

Axles have to support heavy loads over years of service and convert the engine power into motion. SCHÄFFER axles are found exclusively in SCHÄFFER loaders. Loaders and axles are optimally matched. There is no more economical solution. You can depend on it. This is proverbial quality *made by SCHÄFFER*. And all that starting at machine widths of 790 mm.



HIGH POWER, WISELY APPLIED ...

KUBOTA motors: Compact, powerful and reliable. These products from the world's largest manufacturer of compact diesel motors cannot be described more accurately. These motors get the most out of their fuel. The vortex chamber combustion system ensures optimal combustion. The consumption was reduced yet again in the latest generation of motors; the same applies to the fume and soot values. Important for applications in roofed areas. Another practical advantage for you: All service locations, such as oil and fuel filters, are easily accessible.

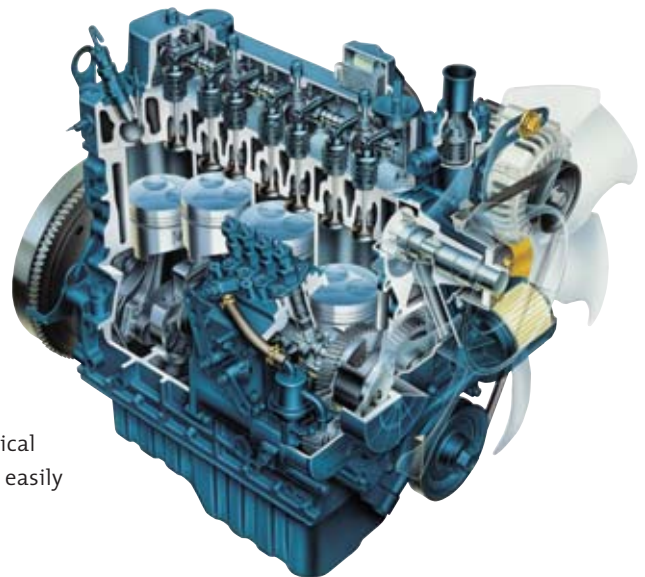

GREASE? NOT HERE, PLEASE.

We trust our articulating linkage so highly that we offer a 3 year or 3000 operating hour warranty on this component. You will hardly notice this component, since it does not need to be greased for the lifetime of the loader.

Schäffer Lader



EXCEPTIONAL COMFORT

Exceptional comfort is provided by the hydrostatic drive. Select the driving direction, start smoothly with any load and accelerate without shifting to the maximum speed of 15 or 20 km/h. The ergonomic control lever lets you determine the driving direction – and gives you sure control over the hydraulics as well. You can move even heavy loads with power and a fine touch. This makes work fun.

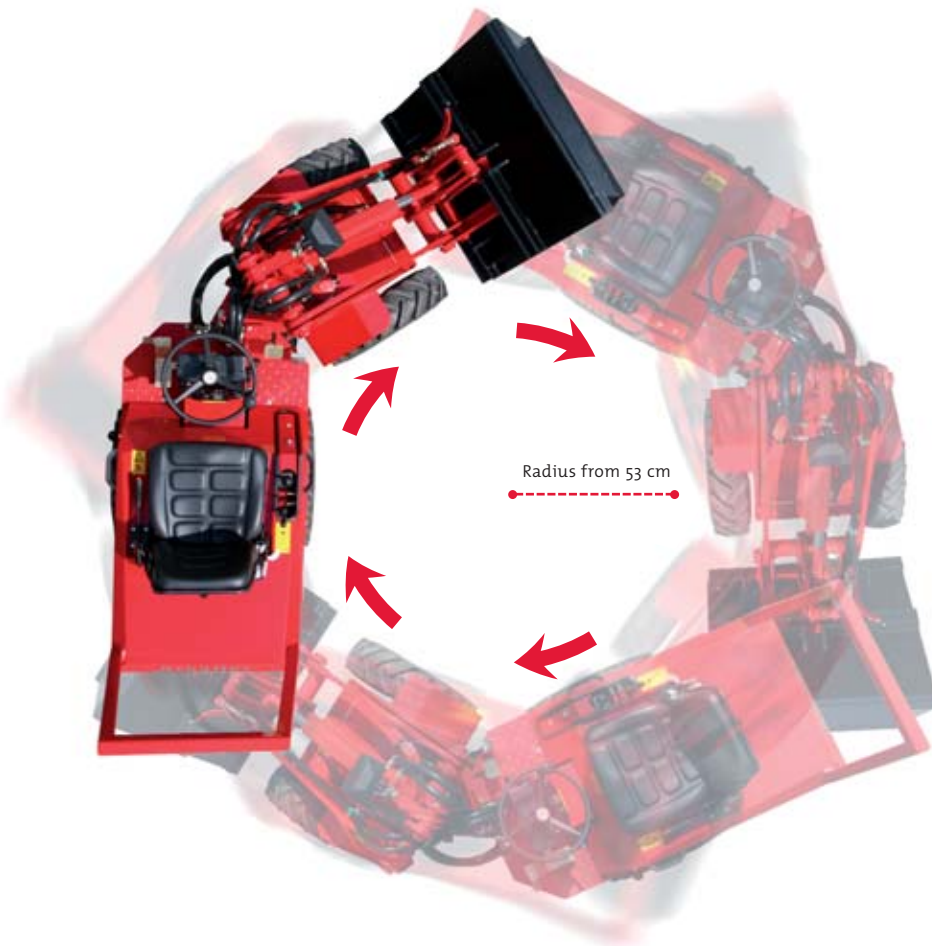

SCHÄFFER loaders are easy to drive. The back wheels track true to the front wheels – an advantage especially in tight corners and narrow passages.

TECHNICAL DATA

	217	221 S	222 S	326 S	336 S	442 S
Motor	3 Cylinder Kubota 15 KW (20 hp)	3 Cylinder Kubota 19 KW (26 hp)	3 Cylinder Kubota 19 KW (26 hp)	3 Cylinder Kubota 24 KW (32 hp)	3 Cylinder Kubota 26,5 KW (36 hp)	3 Cylinder Kubota 35 KW (48 hp)
Drive Hydraulics	Hydraulic Flow Rate: 52 l/min Working Pressure: 180 Bar	Hydraulic Flow Rate: 60 l/min Working Pressure: 180 Bar	Hydraulic Flow Rate: 85 l/min Working Pressure: 300 Bar	Hydrostatic automot- ive Flow Rate: 126 l/min, Working Pressure: 350 Bar	Hydrostatic automotive, 2 ranges electroni- cally shifted from multifunction control lever. Flow Rate: 126 l/min Working Pressure: 350 Bar	
Tires	7.00-12 AS Option I 27x850-15 Option II 27x10,5-15 Option III 26x12.00-12	7.00-12 AS Option I 27x850-15 Option II 27x10,5-15 Option III 26x12.00-12	7.00-12 AS Option I 27x850-15 Option II 27x10,5-15 Option III 26x12.00-12	10.075-15,3 AS Option I 7,5-15,3 AS Option II 31x15,5-15	10.075-15,3 AS Option I 11,5/80- 15,3 AS Option II 15,0/55-17 AS	10.075-15,3 AS Option I 15,0/55-17 Option II 425/55-17
Operating Brake System	Mechanical Drum Brakes	Mechanical Drum Brakes	Hydrostatic	Combination Hydrostatic and multiple-disk	Combination Hydrostatic and multiple-disk	Combination Hydrostatic and multiple-disk
Parking Brake	Mechanical Drum Brakes	Mechanical Drum Brakes	Mechanical Drum Brakes	Multiple Disk in Oil Bath	Multiple Disk in Oil Bath	Multiple Disk in Oil Bath
Operation Hydraulics	Flow Rate: 26 l/min	Flow Rate: 33 l/min	Flow Rate: 33 l/min	Flow Rate: 40 l/min	Flow Rate: 40 l/min	Flow Rate: 48 l/min
Steering Hydraulics	Working Pressure: 180 Bar	Working Pressure: 200 Bar	Working Pressure: 200 Bar	Working Pressure: 200 Bar	Working Pressure: 200 Bar	Working Pressure: 200 Bar
Steering	Fully Hydraulic Articulated Steering	Fully Hydraulic Articulated Steering	Fully Hydraulic Articulated Steering	Fully Hydraulic Articulated Steering	Fully Hydraulic Articulated Steering	Fully Hydraulic Articulated Steering
Lifting Capacity	900 kg	950 kg	950 kg	1,300 kg	1,500 kg	1,800 kg
Tip-over load, straight	700 kg	780 kg	850 kg	1,000 kg	1,100 kg	1,600 kg
Tip-over load, bent	400 kg	420 kg	500 kg	750 kg	850 kg	1,100 kg
Axles	Original SCHÄFFER axles	Original SCHÄFFER axles	Original SCHÄFFER axles	Original SCHÄFFER axles	Original SCHÄFFER axles	Original SCHÄFFER axles
Gross Vehicle Weight	1,495 kg	1,655 kg	1,700 kg	1,970 kg	2,120 kg	2,595 kg
Speed	0 – 12 km/h	0 – 12 km/h	0 – 12 km/h	0 – 15 km/h, continuously variable, optional 0 – 15 km/h	0 – 20 km/h in 2 ranges, can shift under full load.	
Electrical System	Operating Voltage 12 V	Operating Voltage 12 V	Operating Voltage 12 V	Operating Voltage 12 V	Operating Voltage 12 V	Operating Voltage 12 V
Fluid Capacities	Fuel: 15 l Hydraulic Oil: 40 l	Fuel: 15 l Hydraulic Oil: 40 l	Fuel: 15 l Hydraulic Oil: 40 l	Fuel: 28 l Hydraulic Oil: 65 l	Fuel: 38 l Hydraulic Oil: 65 l	Fuel: 48 l Hydraulic Oil: 100 l



DIMENSIONS

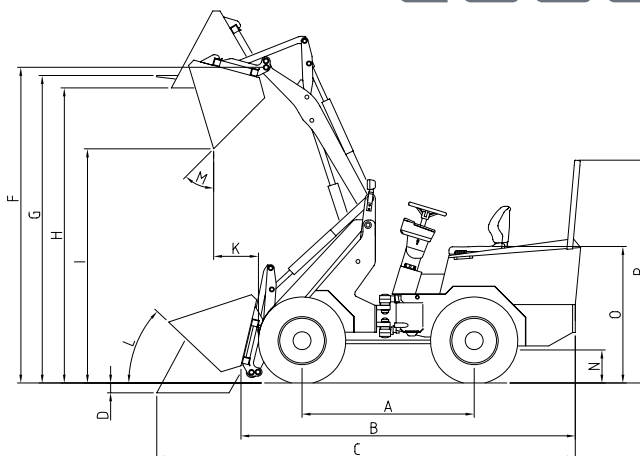
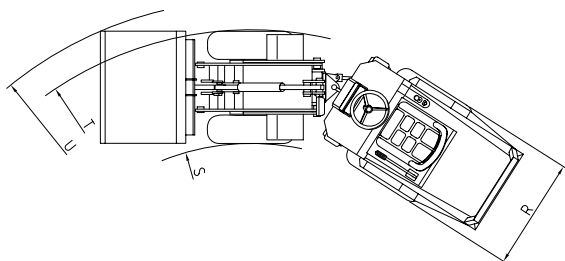

		217	221 S	222 S	326 S	336 S	442 S
A	Wheelbase [mm]	1,375	1,390	1,390	1,540	1,540	1,580
B	Chassis Length [mm]	2,725	2,620	2,620	2,900	3,110	3,310
C	Total Length with standard bucket [mm]	3,360	3,400	3,400	3,650	3,790	4,070
D	Digging depth below grade [mm]	110	110	110	130	130	120
F	Maximum Bucket Pin Height [mm]	2,500 / 2,700*	2,700	2,700	2,810 / 3,090**	2,830 / 3,100**	3,090 / 3,270**
G	Loading Height with Pallet Forks [mm]	2,300 / 2,500*	2,500	2,500	2,710 / 2,990**	2,730 / 3,000**	3,020 / 3,200**
H	Maximum Lift Height [mm]	2.220 / 2.420*	2,420	2,420	2,620 / 2,890**	2,640 / 2,910**	2,880 / 3,060**
I	Maximum Dumping Height [mm]	1,640 / 1,840	1,840	1,840	2,030 / 2,300**	2,050 / 2,320**	2,410 / 2,590**
K	Dumping Width [mm]	600	620	620	520	520	540
L	Bucket Rollback Angle	45°	45°	45°	45°	45°	50°
M	Maximum Dump Angle	55°	45°	45°	45°	45°	50°
N	Ground Clearance [mm]	190	180	180	220	220	240
O	Seat Height [mm]	1,055	1,055	1,055	1,220	1,240	1,270
P	Height of Rollover Bar [mm]	1,700	1,700	1,700	1,950	1,970	2,010
R	Overall Width [mm]	790 – 1,090	890 – 1,090	890 – 1,090	940 – 1,290	1,020 – 1,440	1,220 – 1,420
S	Inner wheel track turning radius [mm]	530	550	550	1,100	1,100	1,300
T	Outer wheel track turning radius [mm]	1,320	1,480	1,480	2,120	2,120	2,550
U	Outer turning radius + Standard Bucket [mm]	1,770	1,950	1,950	2,510	2,510	2,950

* with wide axle ** with high lifting reach





The processes and methods with which SCHÄFFER loaders are developed, built, and serviced is one of a kind. The difference lies in our 50 years of experience. We think first about the operator, for we want to make his work safer, more comfortable, and more profitable as well. To this end, we employ the most modern development and production technologies at our plant in Erwitte, Germany. Lastly, however, it is our associates who work with our customers to continuously develop new solutions. Long years of commitment to the company combined with an insatiable researching spirit form the basis for our exceptional competence and our worldwide success.

The name SCHÄFFER LADER stands for more than one-of-a-kind product quality. It also stands for safety and optimal service, which we guarantee not only in Germany, but also in Europe and around the globe.

The purchase of a SCHÄFFER loader is the beginning of a long-term relationship. Only original replacement parts will allow your machine to remain a 100 % true SCHÄFFER over the years. Only then will it guarantee the reliability which you require and rightfully expect. We offer you and our service partners a 24 hour delivery service – 7 days a week, 365 days a year. And that, too, means ...

made by SCHÄFFER

SCHÄFFER offers you a product line-up with over 40 different models, each of which can be optimally adapted to your requirements. The possible applications for our loaders are numerous: in agriculture or construction, in horticulture or landscaping, in industry and trade, in horse husbandry or in warehousing – SCHÄFFER is always your first choice.



Schaeffer Lader

Your Dealer:

SCHÄFFER MASCHINENFABRIK GMBH
Postfach 10 67 | 59597 Erwitte | Germany
fon +49 02943 9709-0
fax +49 02943 9709-50
info@schaeffler-lader.de
www.schaeffler-lader.de